



8009 E. Dillon's Way  
Scottsdale, AZ 85260  
Technical Support • (800) 223-4570  
(480) 948-8009 • FAX (480) 998-2786

## Dillon's New Dynamic Pistol Dies & Three-Die Rifle Die Sets Instruction Manual, May 2007



### Dillon's "New Dynamic" Pistol Die Sets

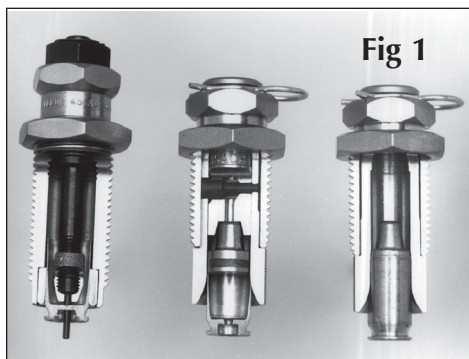
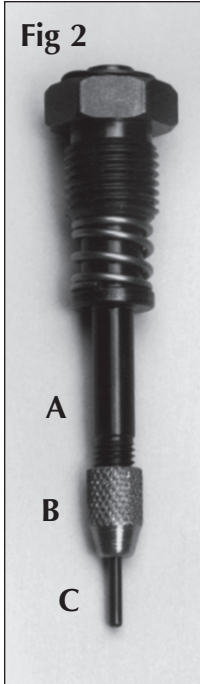

Fig 1. Dillon's New Dynamic Die Set, cut away so that you can see how they look and how they operate. From left to right they are: Full length sizing and decapping die, seating die (with the double ended seating stem) and the crimp die. Note that the seat die and the crimp die have clips on the top to allow the insert to be removed without affecting the critical die adjustments.

**Adjust** the sizing die by screwing the die body down until it contacts the shellplate and snug the lock ring. The decap assembly should be screwed fully into the die at all times.



**Fig 2.** Your New Dynamic Dies are equipped with Dillon's unique "snap spring" decap assembly. The spring on this unit compresses as the decap pin pushes against the spent primer. As the spent primer clears the primer pocket, the spring snaps the pin downward, throwing the spent primer off the pin. This prevents the spent primer from being drawn back into the primer pocket and jamming the machine. The problem of primer "draw back" often occurs when decapping military brass. This exclusive feature is unique to Dillon dies

and at no extra charge. Fig 2 also shows the three main pieces of the decapping stem: **A.** Decapping shaft. **B.** Retaining cap. **C.** Decapping pin.

**Fig 3.** To remove the decap pin, use a 1/8" Allen wrench to hold the decap stem while loosening the retaining cap with a pair of pliers. Use a small amount of 242 (blue) Loctite and tighten securely on reassembly.

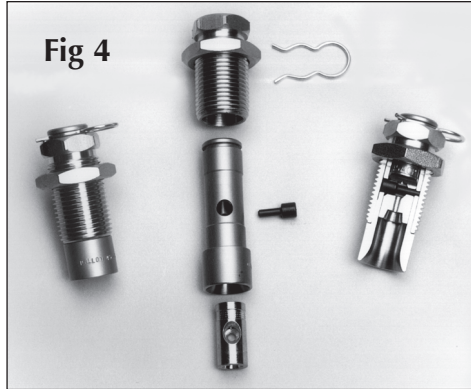
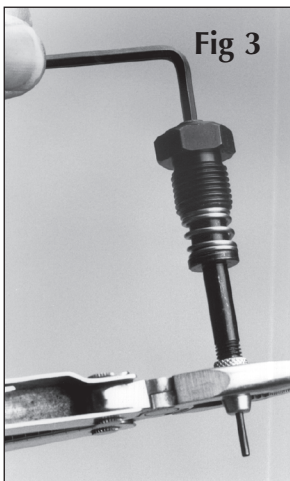

**Fig 4.** Your Dillon Dynamic seating die is a snap-together assembly.

**Fig 5.** The seating die can be disassembled by simply removing the snap ring at the top and pulling the seat die insert out of the bottom of the seat die body. This allows you to take the die apart for cleaning without tools and without disturbing your seating adjustment.

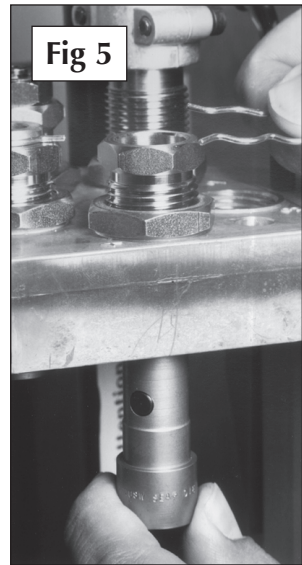

Fig 6. The double-ended seating stem can then be removed for cleaning or changing by pushing out the black cross pin. Note that the seat stem is doubled ended and can be reversed to match the shape of your bullet.



Figs 7 & 8. Choose the seating stem which best fits your bullet.

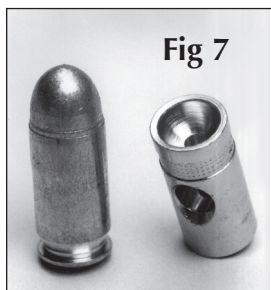

Fig 7 is the round nose seating stem and Fig 8 is the semi-wadcutter seating stem. When the desired configuration is found push the stem back into the insert and replace the cross

pin. Reinsert the seating insert into the die body. Replace the clip and proceed.

**Adjustment.** Place a sized and belled case into the seating station of the shellplate.

Next place a bullet on the mouth of the case and cycle the handle down. Screw the die down until it makes contact with the bullet. Raise the handle a small amount and screw the die down 1/2 turn. Cycle the handle down and raise it to the top. Remove the case with the partially seated bullet and measure the overall length with dial calipers.

Compare the length to that suggested in your loading manual. If the OAL is too long



turn the seating die down in 1/8 turn increments and cycle the handle again.

Repeat the above process until the proper seating depth is achieved.

**Note:** One full turn of the die is approximately 0.070 of an inch. As you get closer to your desired length do not turn the die down in more than 1/8 turn increments. When the desired OAL has been achieved snug the lock ring while the cartridge is in the die.

**Crimp adjustment.** Place a belled case with a seated bullet into the crimping station of the shellplate and, with the die out of the toolhead, cycle the handle down. Leave the handle down and start the die into the toolhead. Screw the die down until it contacts the case.

Now, raise the handle (to pull the cartridge part way out of the die), screw the die down 1/8 of a turn and then lower the handle again. Remove the case from the die and check for the proper crimp. (Note: refer to a loading manual for proper crimp dimension.)

If your case is not crimped enough, place the cartridge back into the shellplate and repeat your adjustments in 1/8 turn increments until you achieve the proper crimp.



Fig 9. Crimp die assembly. On the left the completed assembly is shown before screwing it into the toolhead.

**IMPORTANT** Now is the time to try this round to see that it fits the barrel or cylinder of your gun. Also, if you're loading for a semi-auto, it's a good idea to load 10-20 rounds and fire them. It's depressing to load a thousand rounds and then find out they won't function the action of your gun.

## Dillon Three-Die Rifle Die Sets

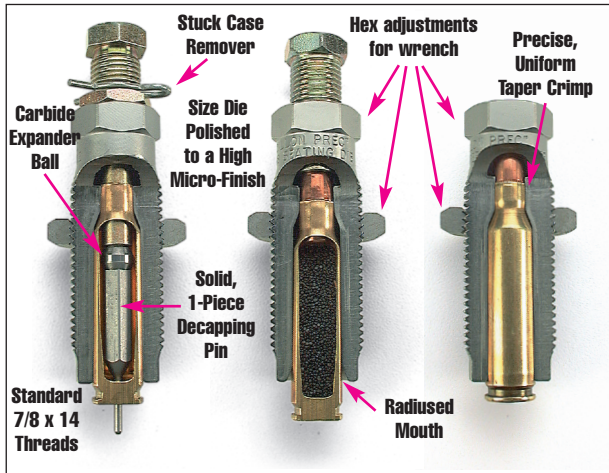

### Dillon Three-Die Rifle Die Sets Include:

- 1- Full-Length Size die, nut, priming assembly with carbide expander
- 1- Seat die, nut, seat stem with nut
- 1- Crimp die, nut and 1- Spare decap pin

### Sizing/Depriming Die

The sizing/depriming die is a full-length sizing die, manufactured to minimum tolerances. We **strongly** suggest that a headspace case gage be used to correctly adjust the size die. Always clean and lube your rifle cases before attempting to process the cases (thru the size die).

1. Move the handle down to raise the platform.
2. Screw the sizing/depriming die into station one of your reloader.
3. When the die contacts the shellplate, back the die off 1/2 turn.
4. Use one lubed rifle case to test your sizing and headspace. Readjust the die as needed to achieve proper headspace.
5. With a case in the die, snug the lock ring.

The depriming assembly includes a carbide expander ball for "squeak free," effortless neck expansion. In the event of a stuck case, the design of the depriming assembly allows it to function as a stuck-case remover. Simply remove the silver clip, loosen the stem lock nut and then spin it up to the top of the stem. With a wrench, turn the depriming assembly into the die. "Clockwise" turns will loosen the stuck case. Use pliers to remove the case from the depriming assembly.

### Bullet Seating Die

Our bullet seating die is internally designed to keep the bullet straight throughout the seating process.

1. Move the handle down, to raise the platform.
2. Screw the bullet seating die into the bullet seating station on your reloader.
3. Put a sized, empty case into the shellplate under the seating die. Pull the handle down. Screw the seat die body down until it stops, then back it up 1/8 of a turn.
4. Refer to your rifle loading manual for proper overall

length (O.A.L.) information.

5. Use only resized, deprimed cases when setting this die. Move the case to the bullet seating station on your reloader
6. Place a bullet on the case and make one complete stroke of the handle.
7. Check the overall length (O.A.L) of the test case and bullet using a quality dial caliper. Adjust the die up or down as needed.
8. With the case and bullet in the die, snug the lock ring.

### Taper Crimp Die

The taper crimp die is configured to center both the case neck and case body, thereby aligning the entire cartridge for a more uniform crimp.

1. Place the test case/bullet you have into the crimp station on your reloader.
2. Move the handle down to raise the platform.
3. Screw the taper crimp die into the crimp station on your reloader.
4. When the die contacts the test case/bullet move the handle up to lower the platform
5. Turn the die 1/4 to a 1/2 turn "clockwise" and try crimping your test case/bullet
6. Use a quality dial caliper to measure the case mouth diameter. Usually, a .002 change is noticed between the neck diameter and the case mouth diameter. Adjust as needed.
7. With the test case/bullet in the die, snug the lock ring.

Refer to the machine operating manual for any further instructions.